

265 Watts

- 180 W Convection & 265 W Forced-cooled Ratings
- 5 V / 3 A Standby Output
- Universal 85 - 264 VAC Input
- IT & Medical Safety Approvals (Class I & II)
- -40° C to +70° C Operation
- Power Fail & Remote On/Off
- Class B Emissions
- 3 Year Warranty

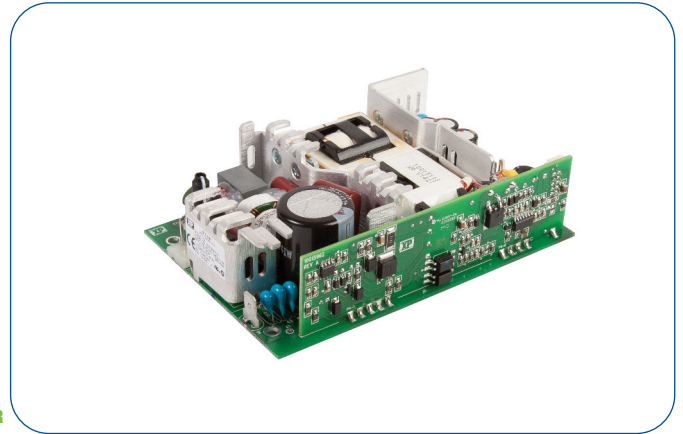

The GCS265 Series has been designed to compliment the existing GCS Series products with the addition of a 5 V/3 A standby

Approved for Class I and Class II applications, the GCS265 is packaged in a 3.5" x 5.0" x 1.43" package and achieves EN55011/32 Level B conducted emissions compliance whilst maintaining very low earth leakage currents, making it suitable for a wide range of 1U and other industrial, IT and medical applications.

The series has single output versions from 12 V to 48 VDC, dual-fusing for compliance with IEC60601-1 and feature minimal excess heat generation as efficiencies reach 94%. They will deliver up to 265 W of power over an operating range of -40 °C to +70 °C and offer inhibit and power fail signals.

Dimensions:

GCS265:

5.00 x 3.50 x 1.43" (127.0 x 88.8 x 36.3 mm)

GCS265-C:

5.50 x 4.01 x 1.72" (139.7 x 101.8 x 43.7 mm)

Models & Ratings

Output Voltage V1	Output Current V1		V Standby Output		V Fan Output	Max Output Power	Model Number ^(1,2,3)
	Convection-cooled	Forced-cooled	Convection-cooled	Forced-cooled			
12.0 VDC	15.0 A	20.8 A	5.0 VDC/2.0 A	5.0 VDC/3.0 A	12.0 VDC/0.6 A	265 W	GCS265PS12
15.0 VDC	12.0 A	16.7 A	5.0 VDC/2.0 A	5.0 VDC/3.0 A	12.0 VDC/0.6 A	265 W	GCS265PS15
24.0 VDC	7.5 A	10.4 A	5.0 VDC/2.0 A	5.0 VDC/3.0 A	12.0 VDC/0.6 A	265 W	GCS265PS24
28.0 VDC	6.4 A	8.9 A	5.0 VDC/2.0 A	5.0 VDC/3.0 A	12.0 VDC/0.6 A	265 W	GCS265PS28
48.0 VDC	3.7 A	5.2 A	5.0 VDC/2.0 A	5.0 VDC/3.0 A	12.0 VDC/0.6 A	265 W	GCS265PS48

Notes

1. To order power supply with optional cover fitted add suffix '-C' to model number, e.g. GCS265PS24-C. Derate to 150W when convection cooled.
2. To order power supply with optional Top Fan Cover fitted add suffix '-TF' to model number, e.g. GCS265PS24-TF
3. To order power supply with optional End Fan Cover fitted add suffix '-EF' to model number, e.g. GCS265PS24-EF

Mechanical Details

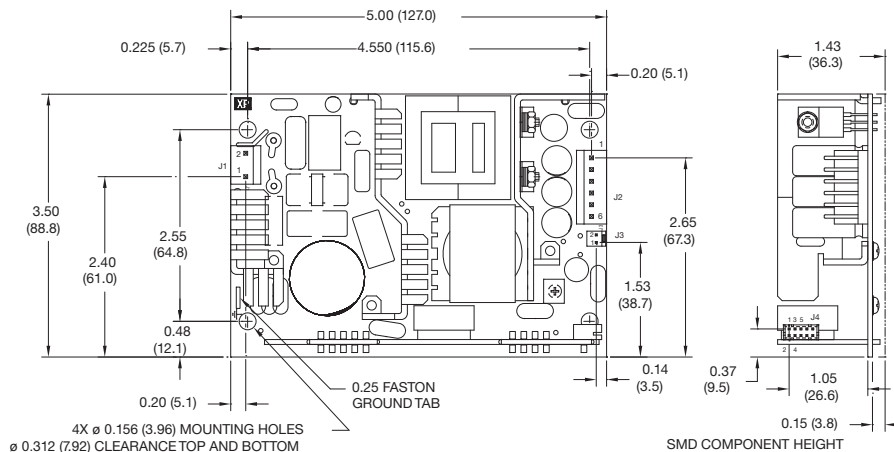

Notes

1. For covered option, refer to page 7, 8 & 9

Input

Characteristic	Minimum	Typical	Maximum	Units	Notes & Conditions
Input Voltage - Operating	85	115/230	264	VAC	Derate output power <90 VAC. See fig 1.
Input Frequency	47	50/60	63	Hz	
Power Factor		>0.9			230 VAC, 100% load
Input Current - Full Load		2.6/1.3		A	115/230 VAC
Inrush Current		80		A	230 VAC cold start 25 °C
No Load Input Power		5.6		W	115V AC
		4.2			230V AC
			0.5		When inhibit is activated
Earth Leakage Current		95 / 185	250	µA	115/230 VAC/50 Hz Typ., 264 VAC/60 Hz Max.
Input Protection	F5.0 A/250 V internal fuse in both lines.				

Output

Characteristic	Minimum	Typical	Maximum	Units	Notes & Conditions
Output Voltage - V1	12		48	VDC	See Models and Ratings table
Initial Set Accuracy			$\pm 1^{(V1)}$ & $\pm 5^{(Vfan)}$	%	50% load, 115/230 VAC
Output Voltage Adjustment - V1	± 2			%	Via potentiometer. See mech. details, Vfan will track
Minimum Load	0			A	
Start Up Delay			0.5	s	115/230 VAC full load
Hold Up Time		10		ms	115/230 VAC full load
Drift			± 0.2	%	After 20 min warm up
Line Regulation			± 0.5	%	90-264 VAC
Load Regulation			$\pm 0.5^{(V1)}$, $\pm 5^{(Vfan)}$	%	0-100% load
Transient Response - V1			4	%	Recovery within 1% in less than 500 µs for a 50-75% and 75-50% load step
Over/Undershoot - V1		5	5.1	%	
Ripple & Noise - V1			1	% pk-pk	20 MHz bandwidth, 12V Models 1.5% max
Overvoltage Protection - V1	110		140	%	Vnom DC. Output 1, recycle input to reset
Overload Protection - V1	110		150	% I nom	See fig. 2. Trip and Restart
Short Circuit Protection - V1					Continuous
Temperature Coefficient			0.05	%/°C	
Overtemperature Protection				°C	Not fitted

Input Voltage Derating Curve

Figure 1

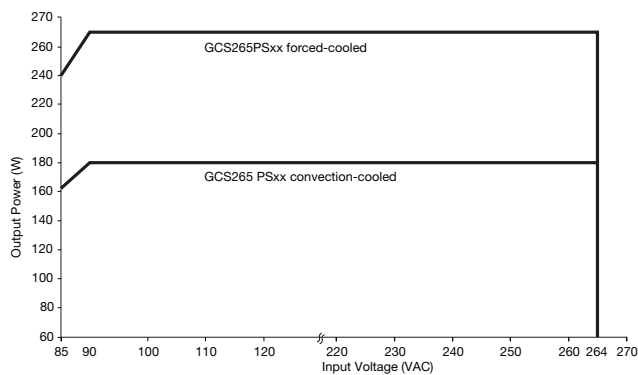

Output Overload Characteristic

Figure 2: GCS265PS12 example (others similar).

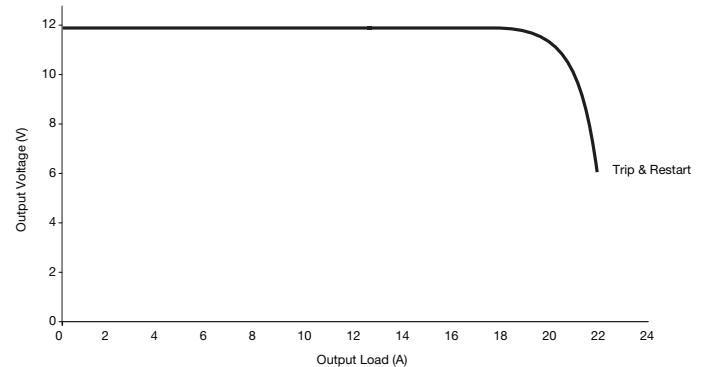

General

Characteristic	Minimum	Typical	Maximum	Units	Notes & Conditions
Efficiency		93		%	230 VAC Full load (see fig.3-5)
Isolation: Input to Output Input to Ground Output to Ground	4000			VAC	
	1500			VAC	
	1500			VAC	
Switching Frequency	60		200	kHz	PFC Converter
	90		150		Main Converter
Power Density			10.7	W/in ³	
Mean Time Between Failure		346		kHrs	MIL-HDBK-217F, Notice 2 +25 °C GB
Weight		0.75 (0.34)		lb (kg)	For open frame version. See mechanical details for weights of other formats.
		0.66 (0.3)			

Efficiency Vs Load

Figure 3
12 V Models

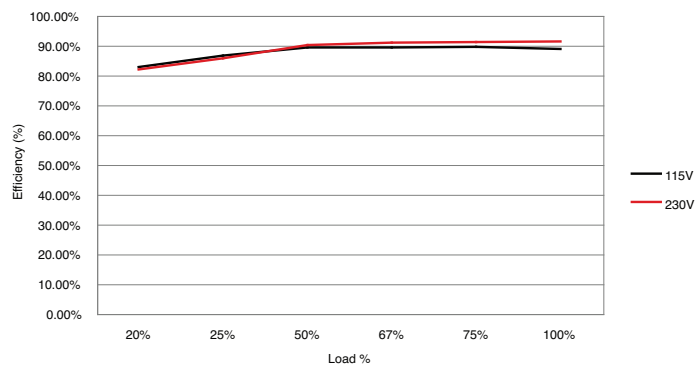

Figure 4
24 V Models

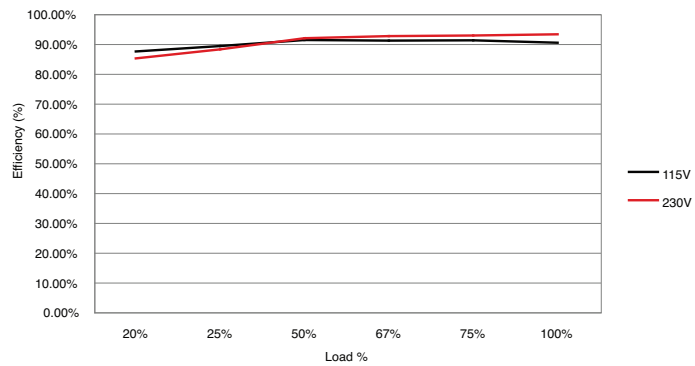
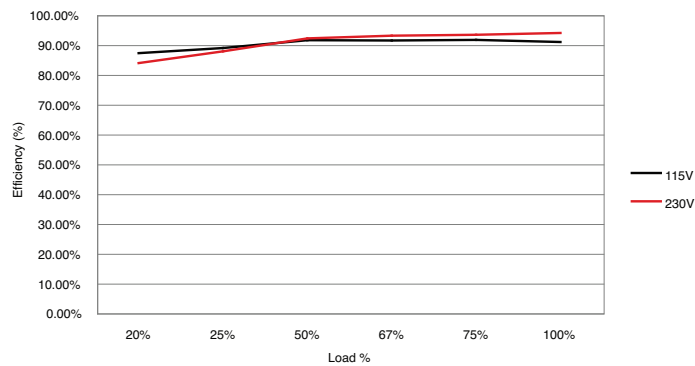

Figure 5
48 V Models



Signals & Controls

Characteristic		Notes & Conditions
Power OK (DC-OK)		Collector pin 6 is internally tied via 10k resistor to +V standby and referenced to -V standby pins 9 & 10 of J4. Provides ≥ 2 ms warning of loss of output from AC failure.
Standby Supply		5 VDC/3.0 A Isolated supply present when AC applied.
Remote Sense		Compensates for 0.5 V total voltage drop
Remote On/Off	Inhibit	The inhibit lo (pin 4), should be pulled below 0.4 V to switch V1 & Vfan off. Open circuit or >4 V to switch on (see fig. 7)
	Enable	With the inhibit lo (pin 4) pulled low as detailed above, connecting inhibit hi (pin 5) to inhibit lo (pin 4) will enable V1 & V fan output. (see fig. 8)

Power OK (DC-OK)

Figure 6

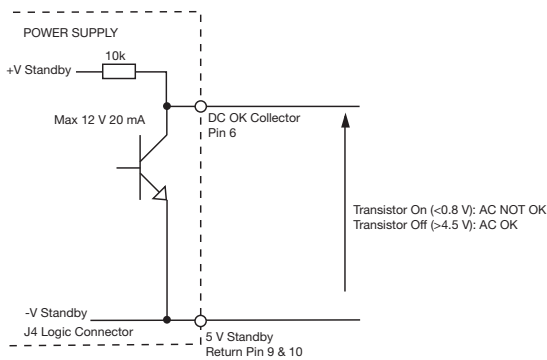

Remote On/Off (Inhibit)

Figure 7

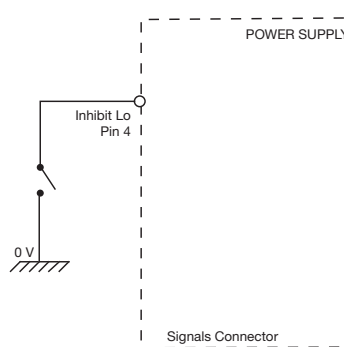

Remote On/Off (Enable)

Figure 8

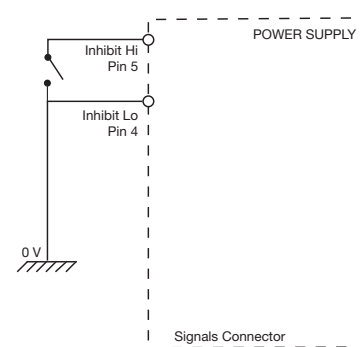

Environmental

Characteristic	Minimum	Typical	Maximum	Units	Notes & Conditions
Operating Temperature	-40		+70	°C	See derating curve, fig. 9
Storage Temperature	-40		+85	°C	
Cooling	7			CFM	Forced Cooled >180 W
Humidity	5		95	%RH	Non-condensing
Operating Altitude			5000	m	
Shock					$\pm 3 \times 30g$ shocks in each plane, total 18 shocks. 30g = 11ms (+/-0.5msec), half sine. Conforms to EN60068-2-27 & EN60068-2-47
Vibration					Single axis 10 - 500 Hz at 2g sweep and endurance at resonance in all 3 planes. Conforms to EN60068-2-6

Thermal Derating Curve

Figure 9

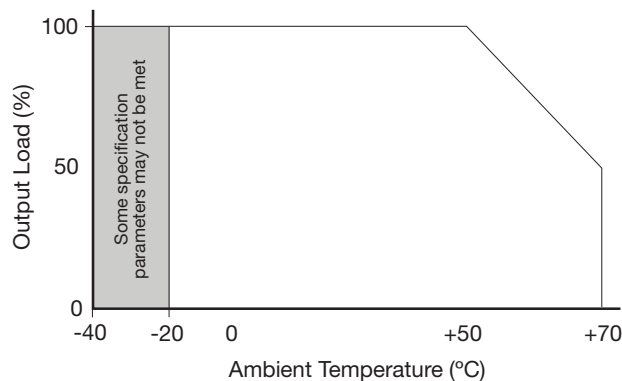

EMC: Emissions

Phenomenon	Standard	Test Level	Criteria	Notes & Conditions
Conducted	EN55011/32	Class B		
Radiated	EN55011/32	Class A		
Harmonic Fluctuations	EN61000-3-3			

EMC: Immunity

Phenomenon	Standard	Test Level	Criteria	Notes & Conditions	
Low Voltage PSU EMC	EN61204-3	High severity level	as below		
Harmonic Current	EN61000-3-3	Class A		All models	
		Class C		> 70 W	
Radiated	EN61000-4-3	3	A		
EFT	EN61000-4-4	3	A		
Surges	EN61000-4-5	Installation class 3	A		
Conducted	EN61000-4-6	3	A		
Dips and Interruptions	EN55024 (100 VAC)	Dip >95% (0 VAC), 8.3ms	A		
		Dip 30% (70 VAC), 416ms	B		
		Dip >95% (0 VAC), 4160ms	B		
	EN55024 (240 VAC)	Dip >95% (0 VAC), 10.0ms	A		
		Dip 30% (168 VAC), 500ms	B		
		Dip >95% (0 VAC), 5000ms	B		
	EN60601-1-2 (100 VAC)	Dip >95% (0 VAC), 10.0ms	A		
		Dip 60% (40 VAC), 100ms	A		Derate Output Power to 120 W
		Dip 30% (70 VAC), 500ms	A		
	EN60601-1-2 (240 VAC)	Dip >95% (0 VAC), 5000ms	B		
		Dip >95% (0 VAC), 10.0ms	A		
		Dip 60% (96 VAC), 100ms	A		
		Dip 30% (168 VAC), 500ms	A		
		Dip >95% (0 VAC), 5000ms	B		

Safety Approvals

Safety Agency	Safety Standard	Notes & Conditions
CB Report	IEC60950-1:2005 Ed 2	Information Technology
	IEC60601-1 Ed 3 Including Risk Management	Medical
UL	UL60950-1 (2007), CSA 22.2 No.60950-1-1:08	Information Technology
	ANSI/AAMI ES60601-1:2005 & CSA C22.2, No.60601-1:08	Medical
TUV	EN60950-1:2006	Information Technology
	EN60601-1/A12:2006	Medical
CE	LVD & RoHS	
Equipment Protection Class	Class I & Class II	See safety agency conditions of acceptability for details

Means of Protection	Category
Primary to Secondary	IEC60601-1 Ed 3
Primary to Earth	
Secondary to Earth	

Mechanical Details

Open Frame

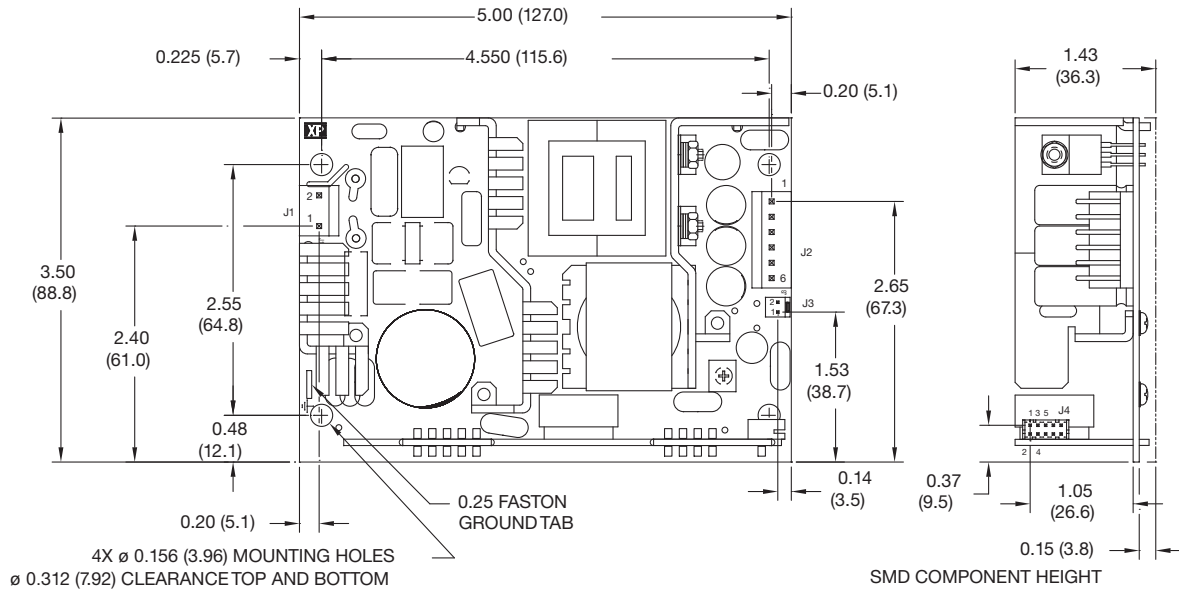

Input Connector J1 Molex pn. 09-65-2038	
Pin	Function
1	Line
2	Neutral

Output Connector J2 Molex pn. 09-65-2068	
Pin	Single Output
1	+V1
2	+V1
3	+V1
4	RTN
5	RTN
6	RTN

Fan Connector J3 Molex pn. 22-04-1021	
Pin	Function
1	Fan +(12 V)
2	Fan -

Signal Connector J4 JST PN B10B-PHDSS	
Pin	Single Output
1	+Sense
2	-Sense
3	XP Internal Use
4	Inhibit LO
5	Inhibit HI
6	Power OK (DC-OK)
7	+V Standby
8	+V Standby
9	-V Standby
10	-V Standby

Notes

- All dimensions in inches (mm).
- Tolerance .xx = ± 0.02 (0.50); .xxx = ± 0.01 (0.25)
- Weight: 0.66 lbs (300 g) approx.
- J1 mates with Molex Housing PN 09-50-1031,
 J2 mates with Molex Housing PN 09-50-1061 and both with Molex series 5194 crimp terminals.
 J3 mates with Molex Housing PN 22-01-1024 and with Molex series 5103 crimp terminals.
 J4 mates with JST Housing PN PHDR-10VS and with JST SPHD-001T-P0.5 crimp terminals.

Mechanical Details

Covered Option (-C)

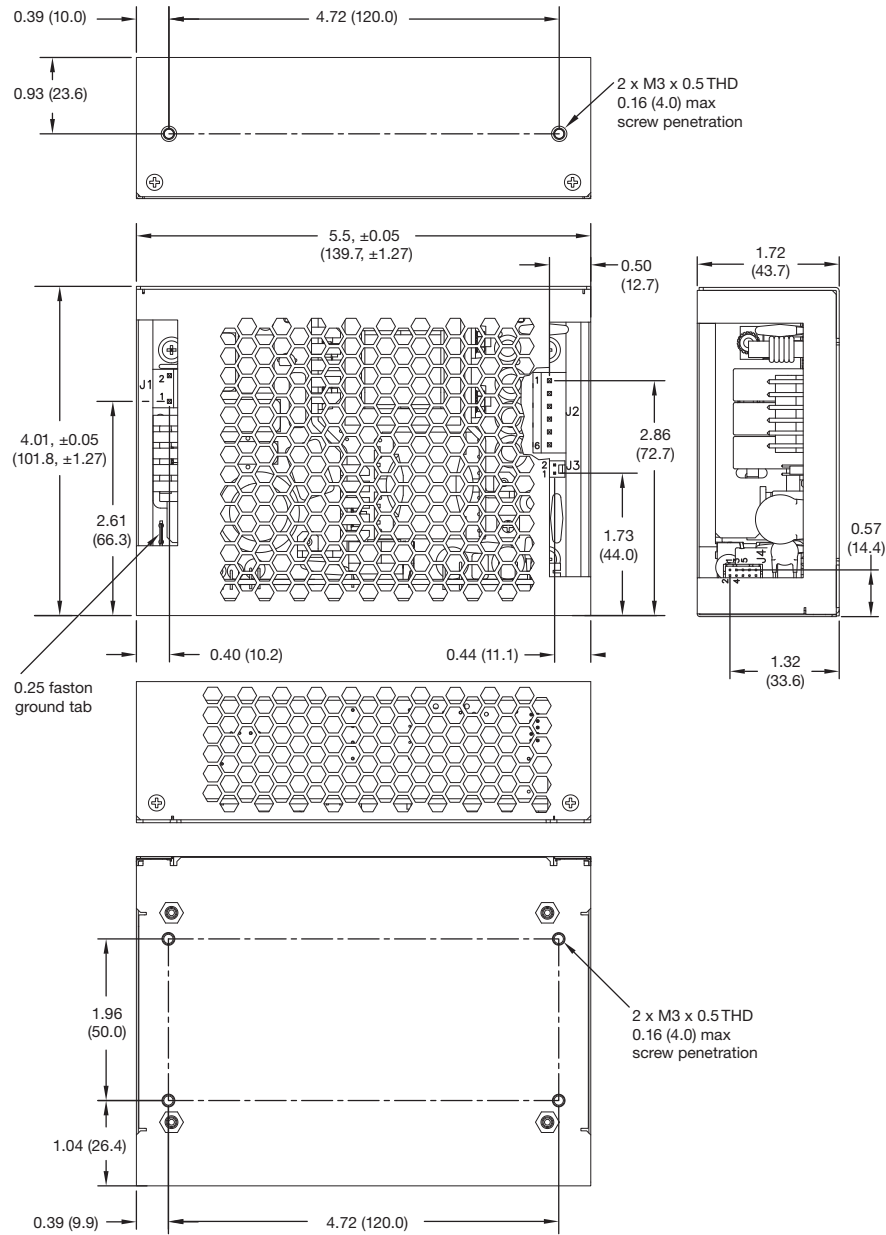

Input Connector J1 Molex pn. 09-65-2038	
Pin	Function
1	Line
2	Neutral

Output Connector J2 Molex pn. 09-65-2068	
Pin	Single Output
1	+V1
2	+V1
3	+V1
4	RTN
5	RTN
6	RTN

Fan Connector J3 Molex pn. 22-04-1021	
Pin	Function
1	Fan +(12 V)
2	Fan -

Signal Connector J4 JST PN B10B-PHDSS	
Pin	Single Output
1	+Sense
2	-Sense
3	XP Internal Use
4	Inhibit LO
5	Inhibit HI
6	Power OK (DC-OK)
7	+V Standby
8	+V Standby
9	-V Standby
10	-V Standby

Notes

- All dimensions in inches (mm).
- Tolerance .xx = ±0.02 (0.50); .xxx = ±0.01 (0.25), except where shown
- Weight: 1.08 lbs (490 g) approx.
- Derate to 150W when convection cooled.
- J1 mates with Molex Housing PN 09-50-1031,
J2 mates with Molex Housing PN 09-50-1061 and both with Molex series 5194 crimp terminals.
J3 mates with Molex Housing PN 22-01-1024 and with Molex series 5103 crimp terminals.
J4 mates with JST Housing PN PHDR-10VS and with JST SPHD-001T-P0.5 crimp terminals.

Mechanical Details

Top Fan (-TF)

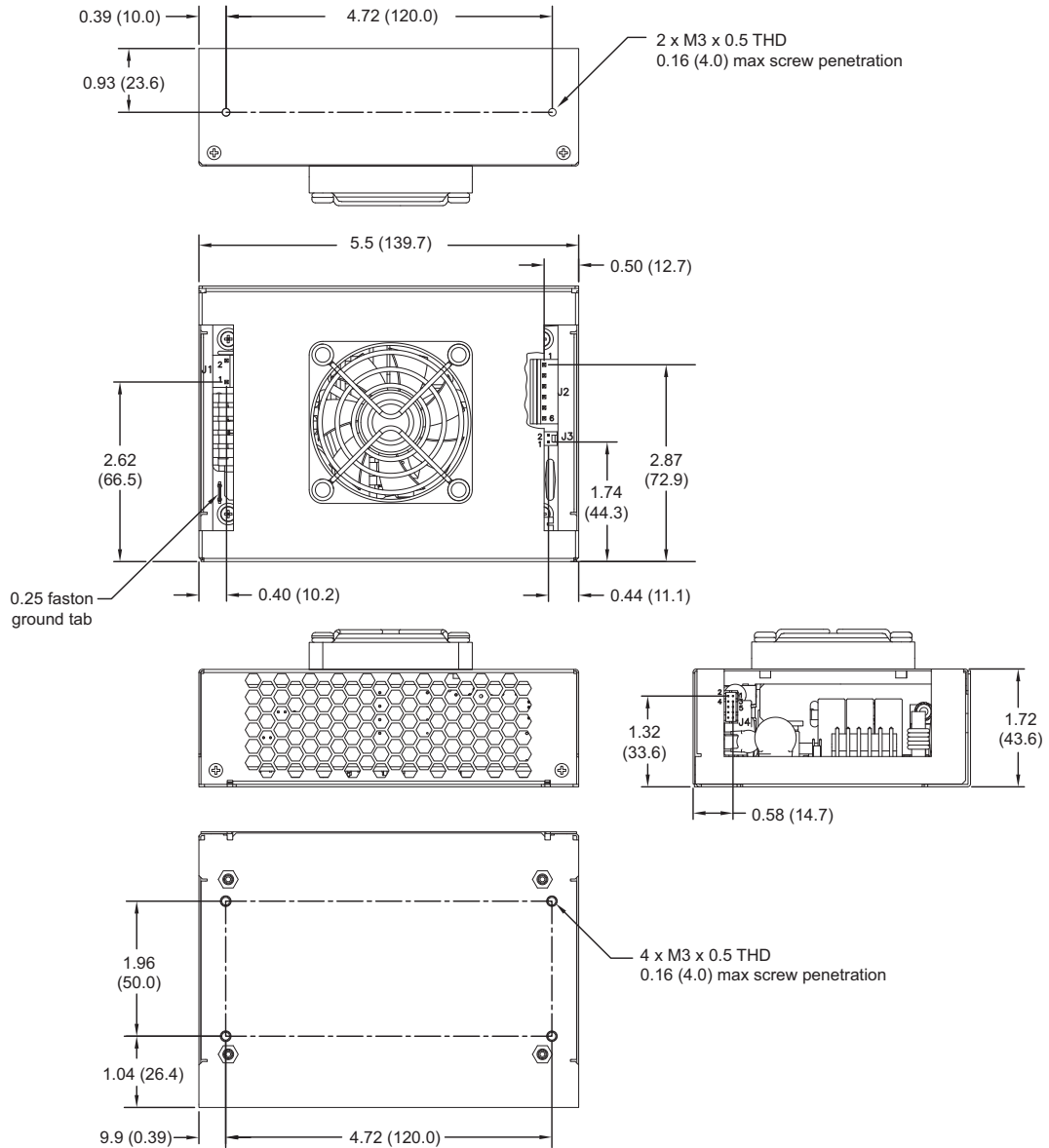

Input Connector J1 Molex pn. 09-65-2038	
Pin	Function
1	Line
2	Neutral

Output Connector J2 Molex pn. 09-65-2068	
Pin	Single Output
1	+V1
2	+V1
3	+V1
4	RTN
5	RTN
6	RTN

Fan Connector J3 Molex pn. 22-04-1021	
Pin	Function
1	Fan +(12 V)
2	Fan -

Signal Connector J4 JST PN B10B-PHDS5	
Pin	Single Output
1	+Sense
2	-Sense
3	XP Internal Use
4	Inhibit LO
5	Inhibit HI
6	Power OK (DC-OK)
7	+V Standby
8	+V Standby
9	-V Standby
10	-V Standby

Notes

- All dimensions in inches (mm).
- Tolerance .xx = ± 0.02 (0.50); .xxx = ± 0.01 (0.25)
- Weight: 1.17 lbs (530 g) approx.
- J1 mates with Molex Housing PN 09-50-1031,
J2 mates with Molex Housing PN 09-50-1061 and both with Molex series 5194 crimp terminals.
J3 mates with Molex Housing PN 22-01-1024 and with Molex series 5103 crimp terminals.
J4 mates with JST Housing PN PHDR-10VS and with JST SPHD-001T-P0.5 crimp terminals.

Mechanical Details

End Fan (-EF)

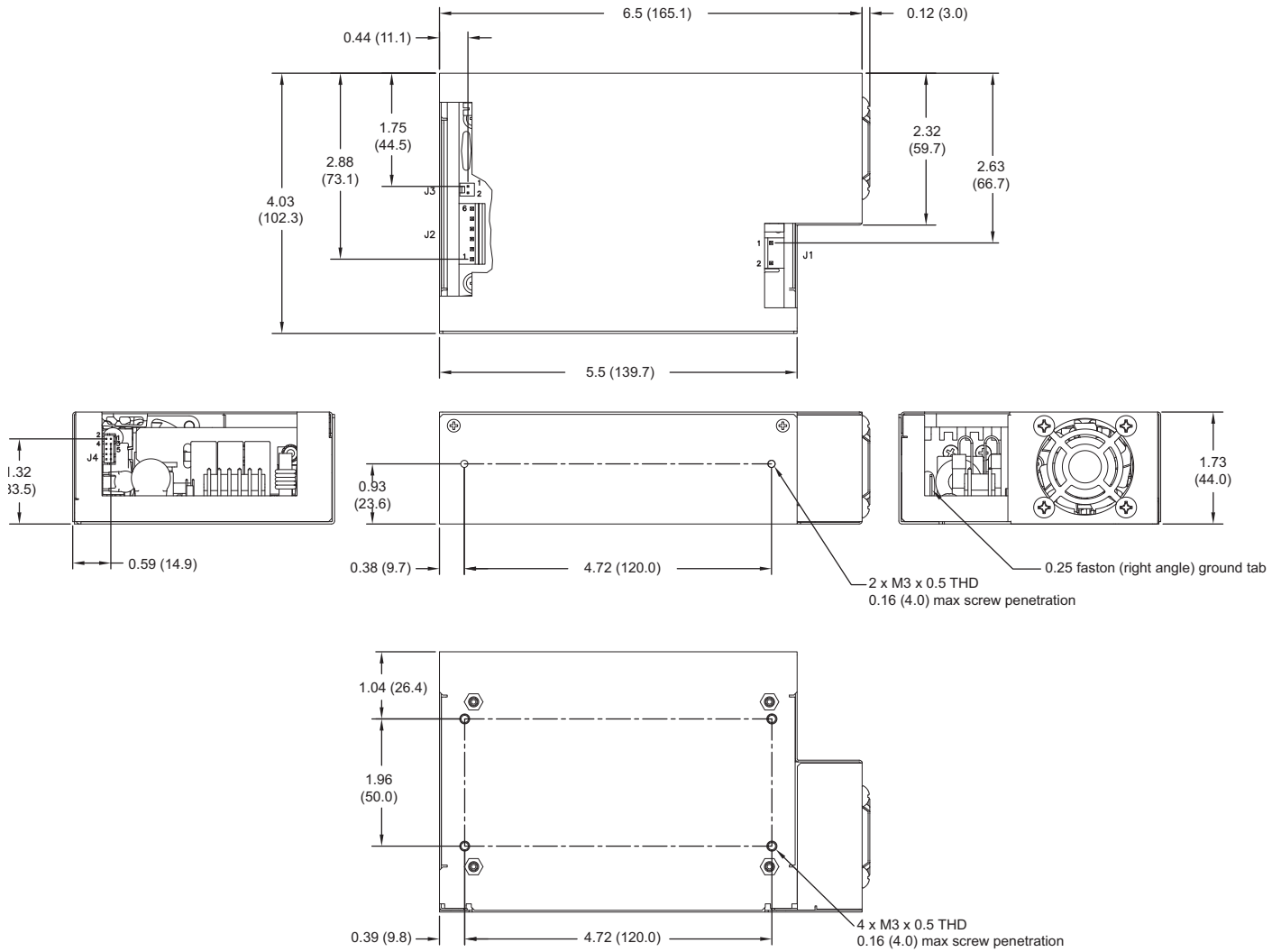

Input Connector J1 Molex pn. 09-65-2038	
Pin	Function
1	Line
2	Neutral

Output Connector J2 Molex pn. 09-65-2068	
Pin	Single Output
1	+V1
2	+V1
3	+V1
4	RTN
5	RTN
6	RTN

Fan Connector J3 Molex pn. 22-04-1021	
Pin	Function
1	Fan +(12 V)
2	Fan -

Signal Connector J4 JST PN B10B-PHDSS	
Pin	Single Output
1	+Sense
2	-Sense
3	XP Internal Use
4	Inhibit LO
5	Inhibit HI
6	Power OK (DC-OK)
7	+V Standby
8	+V Standby
9	-V Standby
10	-V Standby

Notes

- All dimensions in inches (mm).
- Tolerance .xx = ±0.02 (0.50); .xxx = ±0.01 (0.25)
- Weight: 1.32 lbs (600 g) approx.
- J1 mates with Molex Housing PN 09-50-1031,
J2 mates with Molex Housing PN 09-50-1061 and both with Molex series 5194 crimp terminals.
J3 mates with Molex Housing PN 22-01-1024 and with Molex series 5103 crimp terminals.
J4 mates with JST Housing PN PHDR-10VS and with JST SPHD-001T-P0.5 crimp terminals.

Thermal Considerations

In order to ensure safe operation of the PSU in the end-use equipment, the temperature of the components listed in the table below must not be exceeded. Temperature should be monitored using K type thermocouples placed on the hottest part of the component (out of direct air flow). See below for component locations.

Temperature Measurements (At Ambient 50 °C)	
Component	Max Temperature °C
T1 Coil	120 °C
L3 Coil	120 °C
Q1 Body	120 °C
Q3 Body	120 °C
C6	105 °C
C23	105 °C

Service Life

The estimated service life of the GCS265 Series is determined by the cooling arrangements and load conditions experienced in the end application. Due to the uncertain nature of the end application this estimated service life is based on the actual measured temperature of a key capacitors with in the product when installed by the end application. The worst case of the two figures should be taken as the indicative service life in 24/7 operation.

The graph below expresses the estimated lifetime of a given component temperature and assumes continuous operation at this temperature.

Estimated Service Life vs Component Temperature

