

25 Watts

- Regulated Single Output
- Covers all nominal inputs from 24 to 110 VDC for Railway Applications
- Wide 10:1 Input Range
- 3000 VDC Isolation
- High Efficiency
- EN50155 Certified for Railway Applications
- EN50121-3-2 with External Components
- Remote On/Off
- Output Voltage Trim $\pm 10\%$
- Operating Temperature $-40\text{ }^{\circ}\text{C}$ to $+100\text{ }^{\circ}\text{C}$
- Full Power to $+55\text{ }^{\circ}\text{C}$
- 3 Year Warranty



Dimensions:

RDF25:

2.0 x 1.0 x 0.45" (50.8 x 25.4 x 11.5 mm)

The RDF25 series provides an exceptional 10:1 input voltage of 16-160V DC covering all requirements of the railway standard EN50155. The product features a robust design tested to railway standards and includes a remote on /off function, output voltage trimming, protection against short circuit, undervoltage lockout, overtemperature, overload and overvoltage.

Models & Ratings

Input voltage	Output voltage	Output current	Input current ⁽¹⁾		Maximum capacitive load	Efficiency	Model number
			No load	Full load			
16-160VDC	5.0V	5000 mA	10 mA	413.36 mA	6800 μF	85%	RDF2572S05
	12.0V	2080 mA		412.70 mA	1000 μF	84%	RDF2572S12
	15.0V	1670 mA		409.31 mA	820 μF	85%	RDF2572S15
	24.0V	1040 mA		407.84 mA	470 μF	85%	RDF2572S24

Notes

1. Input current measured at nominal input voltage.

2. For heatsink add suffix '-HK', e.g. RDF2572S15-HK

Mechanical Details

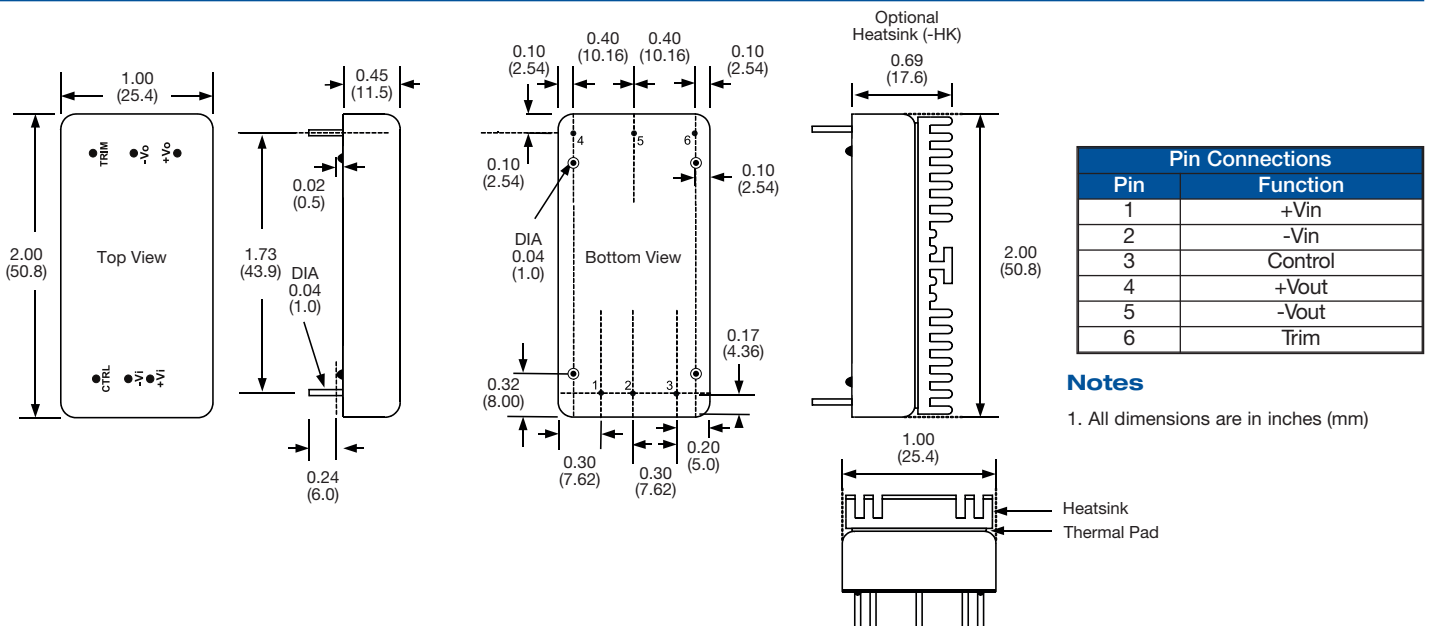

Input

Characteristic	Minimum	Typical	Maximum	Units	Notes & Conditions
Input Voltage Range	16		160	VDC	24 V, 37.5 V, 48 V, 72 V, 96 V & 110 V nominal inputs
Input Filter	Internal Pi type				
Input Voltage Surge			176	VDC for 100 ms	
Undervoltage Lockout	OFF at 12 V, ON at 13.8 V				
Remote On/Off (Positive Logic)	ON at 3.0 VDC to 12.0 VDC or open circuit				Positive logic reference to -Vin (pin 2)
	OFF at 0 VDC to 1.2 VDC or short pin 2 to pin 3				
Standby Mode		3		mA	When module inhibited

Output

Characteristic	Minimum	Typical	Maximum	Units	Notes & Conditions
Output Voltage	5		24	VDC	See Models and Ratings table
Output Trim			±10	%	
Initial Set Accuracy			±1.0	%	At full load
Minimum Load				A	No minimum load required
Line Regulation			±0.2	%	From minimum to maximum input at full load
Load Regulation			±0.5	%	From 0 to full load
Transient Response			±4	% deviation	Recovery within 1% in less than 500 μs for a 25% load change.
Ripple & Noise			100	mV pk-pk	20 MHz bandwidth. Measured using external 10 μF MLCC
Oversvoltage Protection		120		%	Zener diode clamp
Overload Protection		150		%	
Short Circuit Protection					Continuous trip & restart (hiccup mode), with auto recovery
Maximum Capacitive Load					See Models and Ratings table
Temperature Coefficient			0.02	%/°C	

General

Characteristic	Minimum	Typical	Maximum	Units	Notes & Conditions
Efficiency		85		%	See Models and Ratings table
Isolation: Input to Output	3000			VDC	60 s basic isolation
Isolation Resistance	10 ⁹			Ω	At 3 kVDC
Isolation Capacitance		2000		pF	
Switching Frequency		250		kHz	
Power Density			28	W/in ³	
Mean Time Between Failure	230			khrs	MIL-HDBK-217F, +25 °C GB
Case Material	Copper case with non-conductive plastic base, UL94V-0 rated				
Potting Material	Epoxy UL94V-0				
Fire Protection	Designed to meet EN45545-2				
PCB Pin Material	Tinned copper ø 1.0 mm brass, solder coated				
Lead Free Reflow Solder Process	IPC JEDEC J-STD 020D.1. 260 °C max. 1.5 mm from case. 10 s max.				
Weight		0.079 (36.0)		lb (g)	Standard
		0.104 (47.0)			With heatsink

Environmental

Characteristic	Minimum	Typical	Maximum	Units	Notes & Conditions
Operating Temperature	-40		+100	°C	See derating curve
Maximum Case Temperature			+105	°C	
Overtemperature Protection		115		°C	
Thermal Impedance to Air	9.5			°C/W	Without heatsink
	8.5				With heatsink
Storage Temperature	-55		+125	°C	
Altitude	5000 m operation				
Humidity			95	%RH	Non-condensing
Cooling	IEC/EN 60068-2-1				
Dry Heat	IEC/EN 60068-2-2				
Damp Heat	IEC/EN 60068-2-30				
Shock & Vibration	IEC/EN 61373				

EMC: Emissions

Phenomenon	Standard	Test Level	Notes & Conditions
Railway Equipment	EN50121-3-2		Conducted and Radiated

EMC: Immunity

Phenomenon	Standard	Test Level	Criteria	Notes & Conditions
Railway Equipment	EN50121-3-2			Electromagnetic compatibility for rolling stock apparatus
ESD	EN50121-3-2	±8 kV air discharge, ±6 kV contact	A	
Radiated	EN50121-3-2	20 V/m	A	
EFT/Burst	EN50121-3-2	±2 kV	A	With external capacitor Suggested parts are 100 µF/250 V electrolytic capacitors two in parallel e.g. Ruby-con BXF series
Surge	EN50121-3-2	±2 kV	A	
Conducted	EN50121-3-2	10 V rms	A	See application notes
Magnetic Fields	EN61000-4-8	100 A/m	A	

Safety Approvals

Safety Agency	Safety Standard	Notes & Conditions
IEC	IEC60950-1/IEC62368-1	ITE

Safety Agency	Safety Standard	Notes & Conditions
EN	EN50155	Railway Applications, Electronic Equipment used on Rolling Stock

Application Notes

Remote On/Off – Single Output

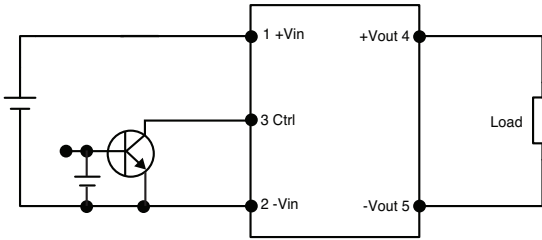

Positive logic. Module turns on with logic high. Logic low turns module off. On/Off is enabled by an external switch between the control pin 3 and -Vin pin 2, e.g. open collector or drain. If the Remote On/Off is not used leave pin 3 floating.

EMC

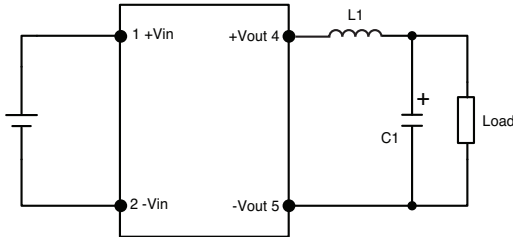

Output Voltage Trim

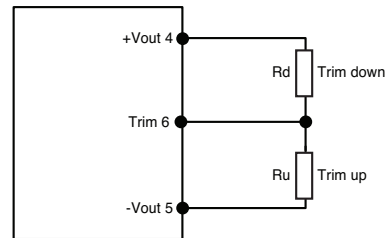

Not applicable for 24 V models

C1	L1
2.2 μ F, 100 V	4.7 μ H

(Electrolytic)

Trim Tables

Trim Down %	5 V	12 V	15 V	24 V
	Rd (k Ω)			
1	248.700	323.351	174.366	881.316
2	110.625	138.100	91.104	466.830
3	66.263	79.928	56.589	293.177
4	44.381	51.470	37.706	197.709
5	31.346	34.591	25.796	137.326
6	22.695	23.418	17.598	95.690
7	16.534	15.477	11.611	65.243
8	11.924	9.542	7.047	42.009
9	8.345	4.939	3.453	23.696
10	5.485	1.264	0.548	8.891

Trim Up%	5 V	12 V	15 V	24 V
	Ru (k Ω)			
1	227.338	367.425	661.510	2846.648
2	109.310	179.645	231.250	955.230
3	68.596	113.623	134.015	542.693
4	47.972	79.929	91.042	362.055
5	35.510	59.489	66.818	260.681
6	27.166	45.767	51.270	195.786
7	21.187	35.919	40.445	150.682
8	16.694	28.508	32.475	117.514
9	13.193	22.728	26.362	92.097
10	10.389	18.094	21.524	71.999

Derating Curve

