

OPTIONS

Analog programming

Many FuG- power supplies are available which differ from the standard design or equipment. On this pages we highlight some of the most common options and modifications. Other customer-specific units having different technical data, different mechanical construction, alternative customer defined interfaces or with extended features are available even for single piece orders.

ANALOG PROGRAMMING:

With this option the output voltage and current of the power supply can be set via

analog voltages (0-10V) or by external potentiometers. Monitor signals of voltage and current (0-10V) available on the programming terminal. An external „ON“-command enables the regulation loop. Selection of manual operation or external programming is possible by a switch on the front panel. This option is also available as a retrofit set for later up gradation of your unit. Usually the „0V“ of the programming voltage is connected to one of the outputs of the unit. If this is not wanted, the unit may be equipped with **floating analog programming**.

FOR THIS VERSION:

→ Isolation max. 2kV DC with respect to the unit output, 30V DC with respect to ground.

On request we can also supply a fibre optic option with isolation capabilities up to 200kV and more.

For most models, the floating analog programming can be installed later at our site.

Pin Configuration: SUB-D 15 pin

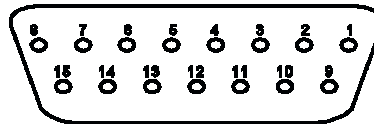

(Solder side of the plug)

PIN	DESCRIPTION	COMMENT
1	Status report: current regulation	regulation active $\hat{=}$ approx. +15V via 10k Ω
2	Status report: voltage regulation	regulation active $\hat{=}$ approx. +15V via 10k Ω
3	Monitor-signal current	"0...nominal value $\hat{=}$ 0...+10V; Ri = 10k Ω (always positive, independent of output polarity)"
4	Slider front plate voltage potentiometer	"0...+10V depending from position of potentiometer knob (not used with isolated analogue programming)"
5	Slider front plate current potentiometer	"0...+10V depending from position of potentiometer knob (not used with isolated analogue programming)"
6	0V for digital signals	
7	"Polarity change for units with electronic polarity reversal (otherwise not used)"	"open = positive connected to 6) = negative"
8	Set value voltage	0...+10V $\hat{=}$ 0...nominal value
9	0V for analogue signals	
10	+ 10 V reference	with reference to pin 9; load up to approx. 2mA
11	Monitor-signal voltage	"0...nominal value $\hat{=}$ 0...+10V; Ri = 10k Ω (always positive, independent of output polarity)"
12	Command: „output ON / OFF“	"open = OFF connected to pin 6 = ON no mains interruption!"
13	"Polarity signalization for units with electronic polarity reversal (otherwise not used)"	"+12V = positive 0V = negative"
14	not used	
15	Set value current	0...+10V $\hat{=}$ 0...nominal value

For single types of equipments, deviations from this configuration are possible (especially for HCN7E, HCB, NLB and custom-designed equipment). In these cases the equipment description is valid.

For proper function of the analog programming at least pin 12 (Output ON/OFF - link to 0V) and both pins 8 and 15 (set values = 0) have to be connected. Using external set value signals, the „0V“ line also has to be connected.

On request we also deliver a complete **remote control** with indicating instruments and set-point potentiometers in a separate case (cable length to 10m), matching to the analog programming.

APPLICATION NOTES FOR THE ANALOG PROGRAMMING:

ONLY EXTERNAL ON / OFF, FRONT SIDE POTENTIOMETERS STAY ACTIVE:

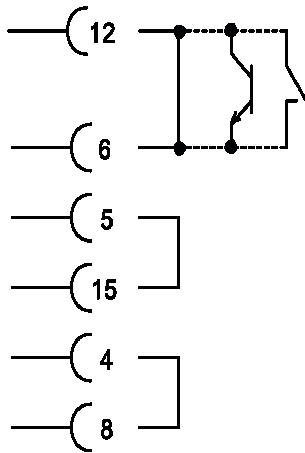

A Link from pin 12 to pin 6 releases the output, a disconnection between these pins locks it. The link can be made by switch, relay contact, wire link, transistor or opto-coupler output (care for correct polarity in the last two cases). Links between pins 15 and 5 and also between 8 and 4 forward the signals of the front plate potentiometers.

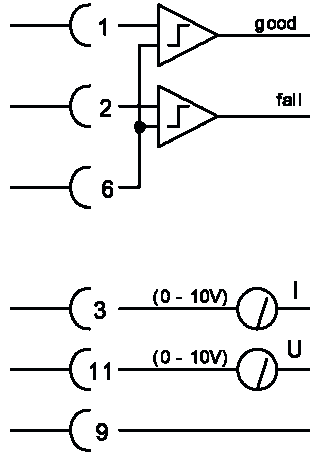

READ SIGNALS IN LOCAL MODE:

These signals can be read out also when the unit is set to local mode by the mode switch at the front plate (switch in position "local"), so that the values are set by the front plate control elements. By analyzing the status signals (pins 1 and 2) via threshold switches for example a good / fail recognising for isolation tests can be created. The indication of monitor values by appropriately calibrated measuring instruments with 0 - 10V is also always possible, independently of the mode of control.

OUTPUT ALWAYS ON, EXTERNAL INPUT OF SET VALUES FOR VOLTAGE AND CURRENT:

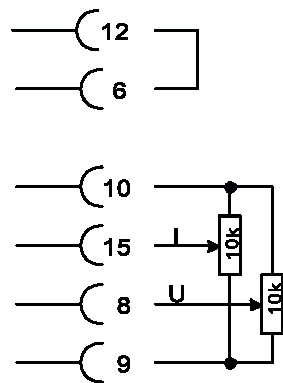

Link between pins 12 and 6 to release the output. 0 - 10V set value input at pins 8 (voltage) and 15 (current). The graphic shows the generation of set values by voltage divider potentiometers, using the internal reference at pin 10. External generation of set values is also possible by digital analog converters or other signal sources.

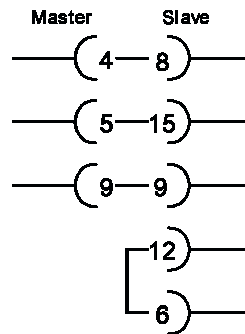

MASTER SLAVE CIRCUIT 1:

Wipers of the front plate potentiometers (pins 4 and 5) of the master unit are connected to the set value inputs of the slave unit (pins 8 and 15). This allows a symmetrical control of two power supplies. Link between pins 12 and 6 is necessary to release the output for the slave unit. (For the master unit this depends on the mode of control.)

OUTPUT ALWAYS ON, ONLY SET VALUE FOR VOLTAGE IS WITH EXTERNAL INPUT, CURRENT LIMITED TO MAXIMUM VALUE.

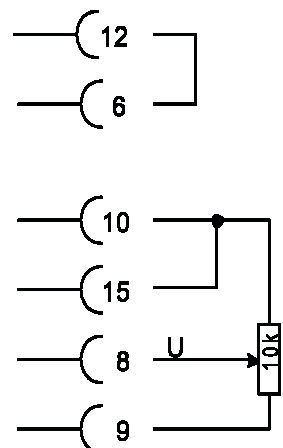

Link between pins 12 and 6 to release the output.

Input of set value only for voltage, pin 15 (set value current) connected to +10V reference, limiting the current to the maximum value by this.

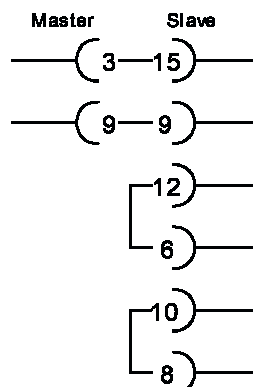

MASTER SLAVE CIRCUIT 2:

The current monitor output (pin 3) of the master is connected to the current set value input (pin 15) of the slave, while the voltage value of the slave is limited to the maximum value (link between pins 10 and 8). This circuit ensures an equal distribution of current with two parallel switched power supplies. The voltage setting is carried out at the master power supply („local“ - or „remote“- control possible.) Link between pins 12 and 6 is necessary to release the output for the slave unit. (For the master unit this depends on the mode of control.)